

The **DFT® Model PDC Check Valve** is a silent, non-slam check valve specially designed for use on the discharge side of reciprocating air or gas compressors. It includes a pulse-damping chamber to maintain the disc in the open position during the momentary reductions in flow associated with each cycle of a reciprocating compressor and to protect against premature seat wear.

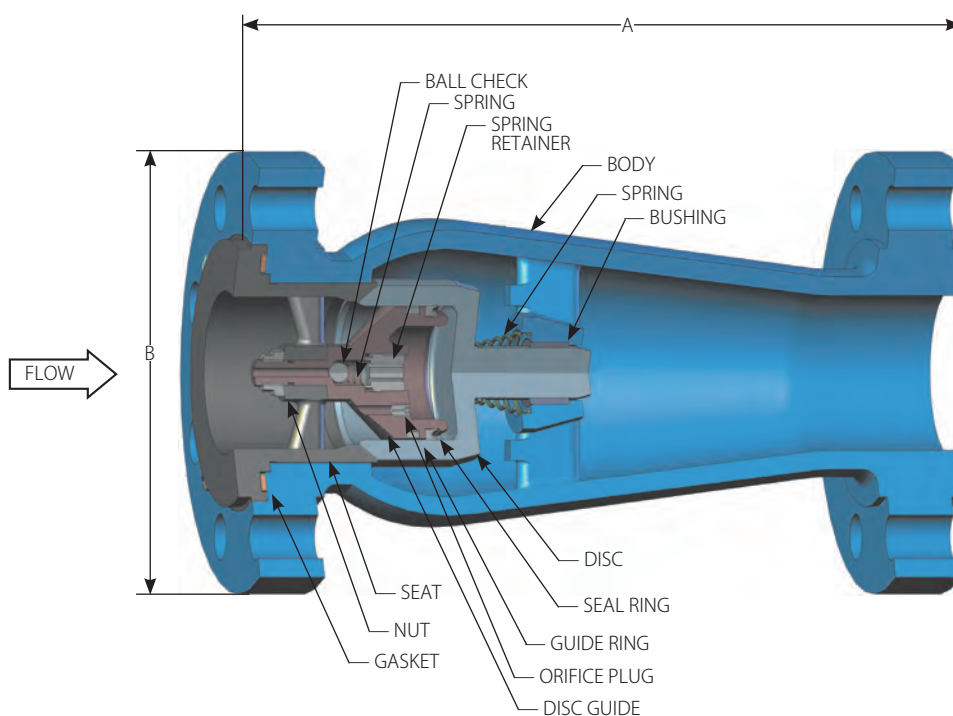

FEATURES:

- Pulse-damped design
- Modulating "air" or "gas" applications:
 - Discharge of reciprocating air/gas compressors
 - Self sizing accommodates varying flows without chattering
- Meets API 6D
- ASME B16.10 Face-to-Face dimensions
- One-piece body
- Spring-assisted silent closing
- 2" to 20" Line size*
- ASME Class 150 to 1500
- Standard body materials:
 - Carbon steel
 - Stainless steel
- Stainless steel trim
- Stainless steel spring
- Ends:
 - RF Flanged
 - RTJ
- Center guided trim
- Horizontal or vertical installation
- Tight shutoff
- Protected spring
- Easy maintenance
- Versatile
- Axial flow
- Nozzle style
- OPTIONS:
 - Soft seat
 - Inconel® X-750 spring
 - Monel® trim
 - NACE (Page 41)



* other sizes available on application

Consult pages 42 and 43 for Pressure/Temperature ratings and soft seat materials.

Class	150 RF	300 RF	600 RF	900 RF	1500 RF	
2"	A	8	10.50	11.50	14.50	14.50
	B	6	6.50	6.50	8.50	8.50
	Weight	20	27	35	65	65
	Cv	62	62	62	55	55
	CP	0.41	0.49	0.41	0.35	0.35
3"	A	9.50	12.50	14	15	18.50
	B	7.50	8.25	8.25	9.50	10.50
	Weight	40	50	58	84	171
	Cv	148	148	142	118	118
	CP	0.62	0.62	0.66	0.78	0.78
4"	A	11.50	14	17	18	*
	B	9	10	10.75	11.50	
	Weight	64	82	117	144	
	Cv	255	255	255	224	
	CP	0.68	0.68	0.31	0.82	
6"	A	14	17.50	22	24	*
	B	11	12.50	14	15	
	Weight	94	149	272	322	
	Cv	660	660	660	567	
	CP	0.51	0.51	0.49	0.63	
8"	A	19.50	21	26	29	*
	B	13.50	15	16.50	18.50	
	Weight	158	293	450	575	
	Cv	1005	1005	1005	740	
	CP	0.66	0.66	0.42	0.60	
10"	A	24.50	24.50	31	*	*
	B	16	17.50	20		
	Weight	260	452	740		
	Cv	1610	1580	1540		
	CP	0.50	0.38	0.46		
12"	A	27.50	28	33	38	44.50
	B	19	20.50	22	24	26.50
	Weight	445	673	1068	1940	2590
	Cv	2300	2300	2300	1990	1590
	CP	0.29	0.29	0.29	.70	0.70

Contact DFT for additional sizes/pressure classes.

MATERIALS OF CONSTRUCTION

COMPONENT	CARBON STEEL BODY	STAINLESS STEEL BODY
Body	A216 Grade WCB	A351 CF8M
Disc	A351 CF8M	A351 CF8M
Seat	A351 CF8M	A351 CF8M
Spring (1)	A313 316 (450°F max.)	A313 316 (450°F max.)
Spring for ball check	Inconel® X-750	Inconel® X-750
Disc Guide	A479 316	A479 316
Bushing	Rulon® (2)	Rulon® (2)
Seal Ring	Teflon®/Hastelloy® C276	Teflon®/Hastelloy® C276
Spring Retainer - Ball Check	A479 316	A479 316
Guide Ring	Teflon®	Teflon®
Ball Check	440C SS	440C SS
Orifice Plug	A479 316	A479 316
Gasket	Durlon® 9000 for 150 & 300, Stainless/Graphite for 600/900/1500 (500°F Maximum)	Durlon® 9000 for 150 & 300, Stainless/Graphite for 600/900/1500 (500°F Maximum)

PDC temperature rating is limited by the spring material and nonmetallic components.

Notes: 1. Inconel® X-750 spring is available. (500°F maximum)
2. 500°F maximum.

* Consult DFT for valve availability.

All dimensions are in inches. Weights are in pounds. For metric measurements, visit www.dft-valves.com. CP: Cracking Pressure (psig)