

WLC®-Cast Iron

The **DFT® Model WLC-Cast Iron Wafer Style Check Valve** is a lightweight, spring-assisted, center-guided, non-slam check valve that provides reliable, low-maintenance service for a wide range of fluids and pressure/temperature combinations. The joint between the seat ring and body is sealed by the flange gasket upon installation, preventing any leakage through the joint when the valve is in service.



FEATURES:

- Wafer design
- Lightweight
- Spring-assisted silent closing
- Center-guided with dual-guided stem
- Horizontal or vertical installation
- Protected spring
- ASME 125 & 250
 - 2" to 10" line size
 - Cast iron body
 - Bronze or 316 SS trim
 - Ends: Wafer FF
 - AWWA seat leakage
- Axial flow
- Nozzle style
- Options:
 - Buna-N Soft Seat

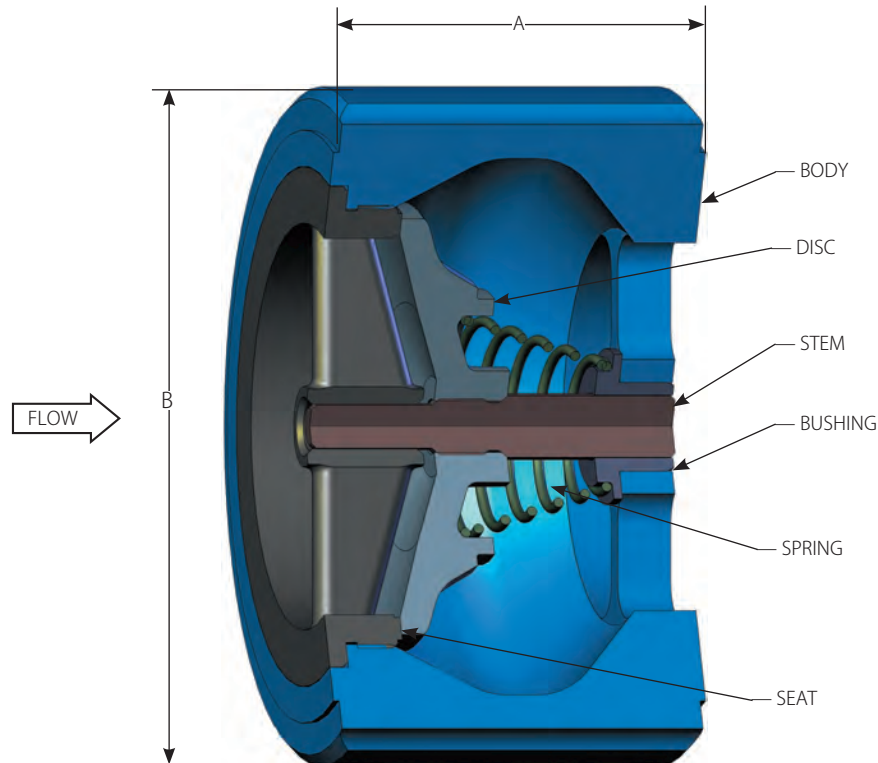

Consult pages 40 and 41 for Pressure/Temperature ratings and soft seat materials.

WLC®-Cast Iron

Class	125 CAST IRON FF	250 CAST IRON FF	
2"	A	2.63	2.63
	B	4.25	4.25
	Weight	6	6
	Cv	66	66
2 1/2"	A	2.88	2.88
	B	5	5
	Weight	7	7
	Cv	88	88
3"	A	3.13	3.13
	B	5.75	5.75
	Weight	12	12
	Cv	130	130
4"	A	4	4
	B	7	7
	Weight	18	18
	Cv	228	228
5"	A	4.75	4.75
	B	8.38	8.38
	Weight	27	27
	Cv	350	350
6"	A	5.50	5.50
	B	9.75	9.75
	Weight	42	42
	Cv	520	520
8"	A	6.50	6.50
	B	13.38	13.38
	Weight	85	86
	Cv	900	900
10"	A	8.25	8.25
	B	16	16
	Weight	129	137
	Cv	1450	1450

PRESSURE TEMPERATURE RATING FOR CAST IRON (PSIG)

Temp. (F°)	CLASS 125	CLASS 250
0-150°	200 psig	400 psig
200° Max (1)	190 psig	370 psig

MATERIALS OF CONSTRUCTION (2)

COMPONENT	CAST IRON BODY/BRONZE TRIM	CAST IRON BODY/316 TRIM (1)
Body	A126 Class B Cast Iron	A126 Class B Cast Iron
Disc/Stem Assembly	B584 836 - Bronze	A351 CF8M
Seat (3)	B584 836 - Bronze	A351 CF8M
Spring	A313 T302 SS	A313 T302 SS
Bushing	B584 836 - Bronze	316 SS

- Notes:**
1. 316 stainless steel trim recommended for temperatures from 180°F to 200°F.
 2. Not recommended for steam service.
 3. Buna-N soft seat available for bubble-tight shutoff.

All dimensions are in inches. Weights are in pounds.