

# SCV-R™

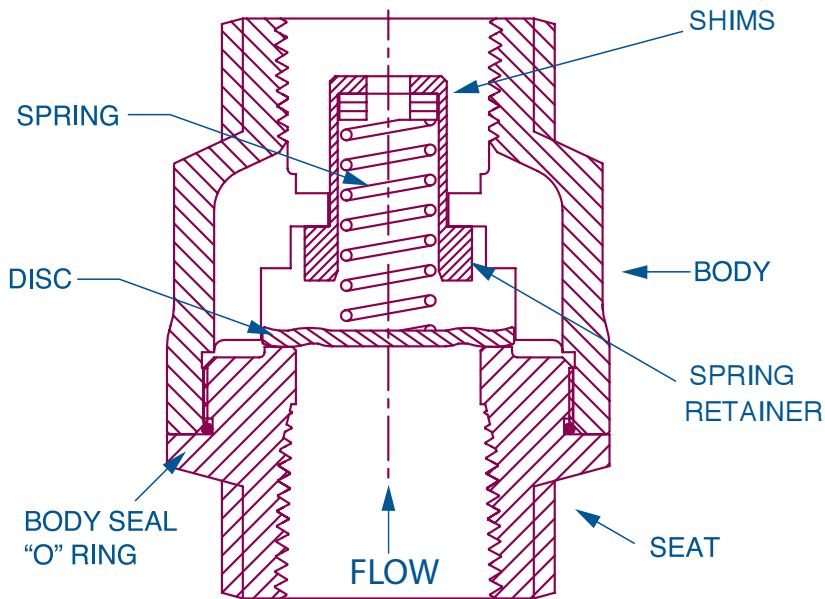

## Features:

- 1/2" to 2" Line size
- 750 CWP
- NPT & SW ends
- Stainless Steel Construction
- Inconel® X-750 spring
- Spring-assisted silent closing, non-slam
- Cracking Pressures: 0.8 to 40.8 psig
- Zelon® body "O" ring
- Horizontal or vertical installation
- Body guided disc
- Tight shut-off - lapped disc & seat
- Simplified construction - 5 parts
- Easy maintenance
- Versatile
- OPTIONS:
  - 316 SS Springs
  - Body seal weld
  - Soft seat
  - Alloy 20 body & seat (ASME 300)
  - Hastelloy C body & seat (ASME 300)
  - NPT x socket weld ends
  - Butt weld ends
  - Repair kits
  - Field conversion kits

The SCV-R is an in-line spring-assisted check valve designed for applications requiring "higher cracking pressures" than the DFT Model SCV® check valve. The SCV-R is a self-contained check valve that installs directly in a pipeline and contains all of the proven features of the SCV check valve.

# SCV-R™

## 750 CWP “Restrictor” Check Valve

	1/2”	3/4”	1”	1 1/4”	1 1/2”	2”
A	2.68	3	3.32	3.87	4.75	5
B (dia.)	1.62	2.13	2.54	3.06	3.44	4.4
Weight	1.1	1.5	1.9	3.9	4.7	7.7
Cv	6	10	17	32	36	64
CP: Cracking Pressure (psig) (+/- 10%)	1.0 to 25	0.8 to 20	1.2 to 23.5	7.7 to 22.2	1.4 to 40.8	0.9 to 21.4

All dimensions are in inches. Weights are in pounds. **Contact DFT for other cracking pressures.**

Pressure Temperature Rating (PSIG)	
Temp. (deg. F)	CWP
-20 to 100°	750
200	645
250 (Buna-N)	610
300 (EPDM)	580
400 (Viton®)	535
470 (Zelon®)	510

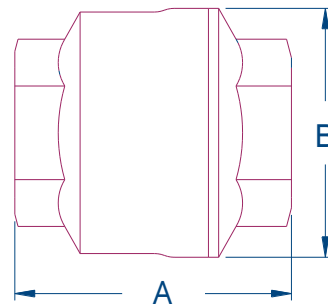

## MATERIALS OF CONSTRUCTION

Body	A351 CF8M
Seat <sup>(1)</sup>	A351 CF8M
Disc	A240 316
Spring	Inconel® X-750
Spring Retainer Assembly	316 SS
“O” Ring	Zelon ( 470° F max.)

- Notes:
1. Soft seats are available for bubble tight shutoff. See chart. Body seal and soft seat material are the same unless otherwise requested.
  2. **Buna-N and Viton are not suitable for steam service.**
  3. Maximum valve temperature rating is limited by the body seal & seat material selected.
  4. 750CWP is rated to 470°F.

MATERIALS	BODY “O” RING/SOFT SEAT MATERIALS <sup>(2)</sup> <sup>(3)</sup>				SPRINGS	
	BUNA-N	EPDM	VITON TFE® - VITON	ZELON® <sup>(4)</sup>	316 SS	INCONEL® X-750
TEMP. °F	-70 to 250	-75 to 300	-40 to 400	37 to 470	-460 to 450	-460 to 700